

# SNORKEL S4726E

## 10M ELECTRIC SCISSOR LIFT

DIMENSIONS	S4726E	S4732E
Max. working height	9.8m	11.8m
Max. platform height (A)	7.8m	9.8m
Platform size (stowed)	1.09m x 2.14m	1.09m x 2.14m
Platform size (extended)	1.09m x 3.36m	1.09m x 3.36m
Extension deck length (B)	1.21m	1.21m
Overall length (with step) (D)	2.3m	2.3m
Overall length (without step)	2.26m	2.26m
Overall width (C)	1.19m	1.19m
Stowed height (E)	2.3m	2.39m
Min. height (guardrails folded)	1.85m	1.94m
Ground clearance (stowed)	66mm	66mm
Ground clearance (elevated)	19mm	19mm

PERFORMANCE		
Platform capacity	454kg	350kg
Max. drive height	7.8m	9.8m
Max. wind speed	12.5m/s	12.5m/s
Max. drive speed (stowed)	3.2km/h	3.2km/h
Max. drive speed (elevated)	0.6km/h	0.6km/h
Raise/lower time	50/58 sec	50/58 sec
Gradeability	25%	25%
Inside turning radius	0.25m	0.25m
Outside turning radius	2.41m	2.41m
Tyres	15 x 5 non-marking rubber	
Controls	proportional	
Drive system	2-wheel drive	

POWER		
Power source	24V DC battery electric	
Charger	90-240V, 25amp	

WEIGHT		
Weight	2,250kg	2,693kg

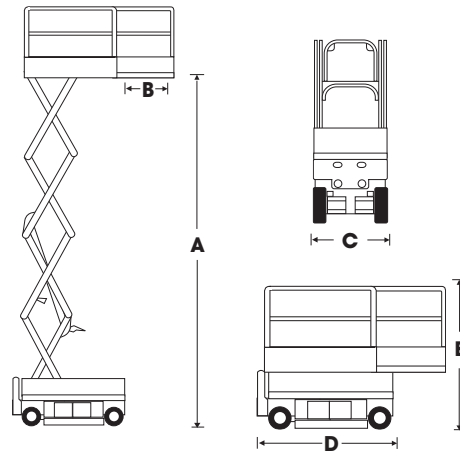

### STANDARD FEATURES

- Roll-out deck extension with dual locks
- Non-marking tyres
- Loading control pendant
- Swing-out service trays
- Saloon-door style entry gates
- Descent alarm
- All motion alarm
- 2 persons indoor
- 1 person outdoor
- Proportional controls, including descent
- Power line to platform
- Hour meter & on-board diagnostics display
- Integrated battery charger
- Battery condition indicator
- Crane & forklift points
- Dual lanyard attachments points
- Flashing amber light
- Scissor stack roller slide plates (set of 2)
- 2 year parts & labour, 5 year structural warranty
- CE approved

### TURNING RADIUS

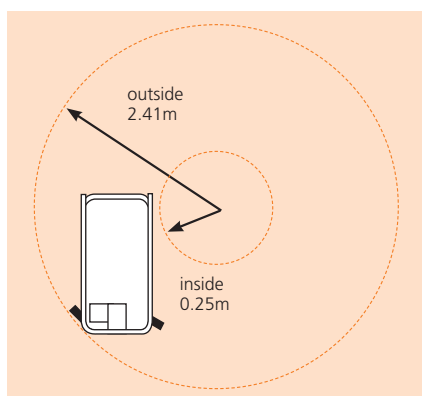

Specifications subject to change without notice. Photos and diagrams in this brochure are for promotional purposes only. Refer to appropriate Snorkel operators manual for detailed instructions on the proper use and maintenance.

**YOUR ONE SUPPLIER FOR EQUIPMENT HIRE, NATIONWIDE.**

**Service area:** Nationwide | **Branches:** New Plymouth & Hawera | **Phone:** 0800 44 10 44 | **Email:** hire@presco.co.nz