

SNORKEL S3219E

7.7M ELECTRIC SCISSOR LIFT

DIMENSIONS	S3215E	S3219E
Max. working height	6.6m	7.79m
Max. platform height (A)	4.6m	5.79m
Platform size (stowed)	0.72m x 1.62m	0.72m x 1.62m
Platform size (extended)	0.72m x 2.53m	0.72m x 2.53m
Extension deck length	0.91m	0.91m
Overall length (with step) (C)	1.78m	1.78m
Overall length (without step)	1.73m	1.73m
Overall width (D)	0.81m	0.81m
Stowed height (B)	2.02m	2.11m
Min. height (guardrails folded)	1.59m	1.65m
Ground clearance (stowed)	66mm	66mm
Ground clearance (elevated)	19mm	19mm

PERFORMANCE		
Platform capacity (SWL)	272kg	250kg
Max. drive height	4.6m	5.79m
Max. wind speed	12.5m/s	12.5m/s
Max. drive speed (stowed)	3.2km/h	3.2km/h
Max. drive speed (elevated)	0.6km/h	0.6km/h
Raise/lower time	20/36 sec	20/38 sec
Gradeability	25%	25%
Inside turning radius	0.1m	0.1m
Outside turning radius	1.63m	1.63m
Tires	12 x 4 non-marking rubber	
Controls	proportional	
Drive system	2-wheel drive	

POWER	
Power source	24V DC battery electric
Charger	90 - 240V, 25amp

WEIGHT		
Weight	1,227kg	1,438kg

TURNING RADIUS

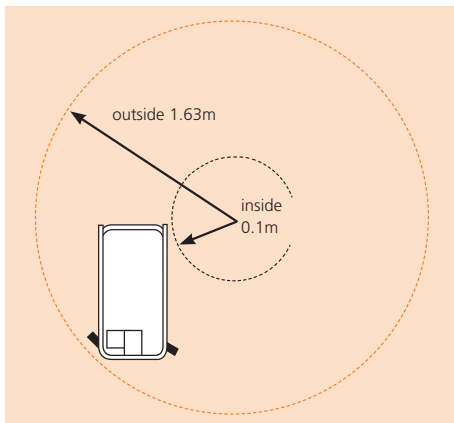

Specifications subject to change without notice. Photos and diagrams in this brochure are for promotional purposes only. Refer to appropriate Snorkel operators manual for detailed instructions on the proper use and maintenance.

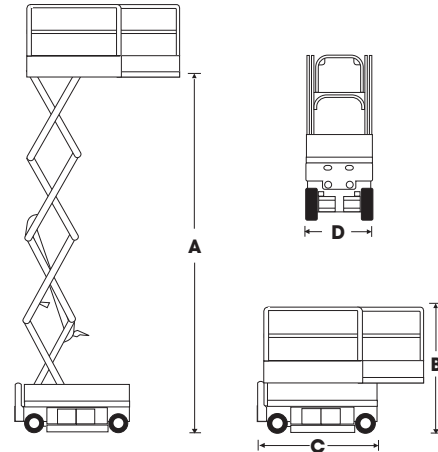

STANDARD FEATURES

- Roll-out deck extension with dual locks
- Non-marking tyres
- Loading control pendant
- Swing-out service trays
- Saloon-door style entry gates
- Descent alarm
- All motion alarm
- 2 persons indoor
- 1 person outdoor
- Proportional controls, including descent
- Power line to platform
- Hour meter & on-board diagnostics display
- Integrated battery charger
- Battery condition indicator
- Crane & forklift points
- Dual lanyard attachments points
- Flashing amber light
- Scissor stack roller slide plates (set of 2)
- 2 year parts & labour, 5 year structural warranty
- CE approved

YOUR ONE SUPPLIER FOR EQUIPMENT HIRE, NATIONWIDE.

Service area: Nationwide | **Branches:** New Plymouth & Hawera | **Phone:** 0800 44 10 44 | **Email:** hire@presco.co.nz