

MANITOU MHT10130

13T TELEHANDLER

Capacities		Metric
Max. capacity	Q	13000 kg
Load centre of gravity	c	600 mm
Max. lifting height	h3	9.65 m
Max. Reach	l4	5.17 m
Weight and dimensions		
Unladen weight (with forks)		18490 kg
Ground clearance	m4	0.44 m
Wheelbase	y	3.37 m
Overall width	b1	2.51 m
Overall height	h17	2.99 m
Overall cab width	b4	0.93 m
Tilt-down angle	a5	117 °
Tilt-up angle	a4	18 °
External turning radius (over tyres)	Wa1	5.34 m
Outer turning radius (with forks)	b15	5.34 m
Forks length / width / section	l / e / s	70 mm x 1200 mm x 200 mm
tires		
Standard tyres		Aeolus - A2233 - 17.5 R25
Number of front wheels / rear wheels		2 / 2
Steering wheels (front / rear)		2 / 2
Drive wheels (front / rear)		2 / 2
Steering mode		2 wheel steer, 4 wheel steer, Crab mode
Engine		
Engine brand		Mercedes
Engine norm		Stage IV / Tier 4 Final
Engine model		OM 934 LA. E4-3
Number of cylinders / Capacity of cylinders		4 - 5100 cm ³
I.C. Engine power rating / Power (kW)		176 Hp / 129 kW
Max. torque / Engine rotation		750 Nm/m@1600 tr/min
Engine cooling system		Water
Number of batteries		2
Battery / Batteries capacity		12 V / 120 Ah
Drawbar pull (Laden)		10800 daN
Transmission		
Transmission type		Hydrostatic
Number of gears (forward / reverse)		2 / 2
Max. travel speed (may vary according to applicable regulations)		31 km/h
Parking brake		Automatic Negative Hand-brake
Service brake		Oil-immersed multi-discs on front & rear axles
Gradeability - laden		34 %
Hydraulics		
Hydraulic pump type		Variable pump
Hydraulic flow - Pressure		180 l/min - 300 Bar
Tank capacities		
Engine oil		21 l
Hydraulic oil		290 l
Fuel tank		315 l
Diesel Exhaust fluid (AdBlue® type)		63 l
Noise and vibration		
Noise at driving position (LpA)		80 dB(A)
Noise to environment (LwA)		107 dB(A)
Vibration on hands/arms		2.5 m/s
Miscellaneous		
Safety cab homologation		Cab ROPS - FOPS Level 2
Controls		JSM
Attachment recognition system (E-Reco)		Standard

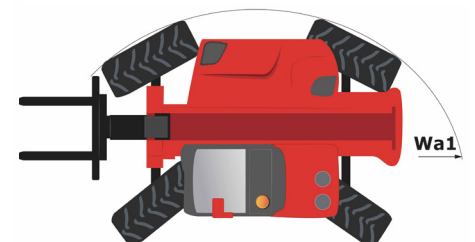
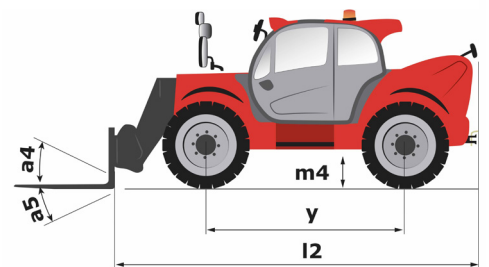
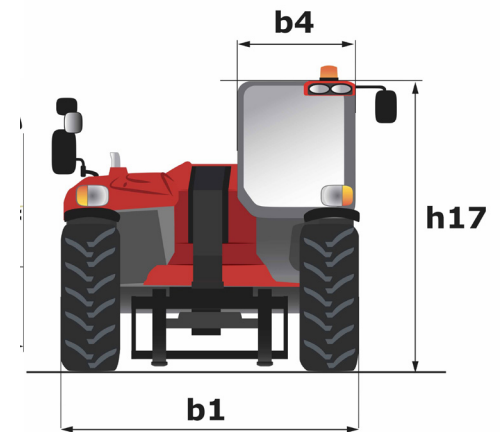

YOUR ONE SUPPLIER FOR EQUIPMENT HIRE, NATIONWIDE.

Service area: Nationwide | **Branches:** New Plymouth & Hawera | **Phone:** 0800 44 10 44 | **Email:** hire@presco.co.nz