

DOOSAN DX140

15T-19T STEEL TRACKED EXCAVATOR

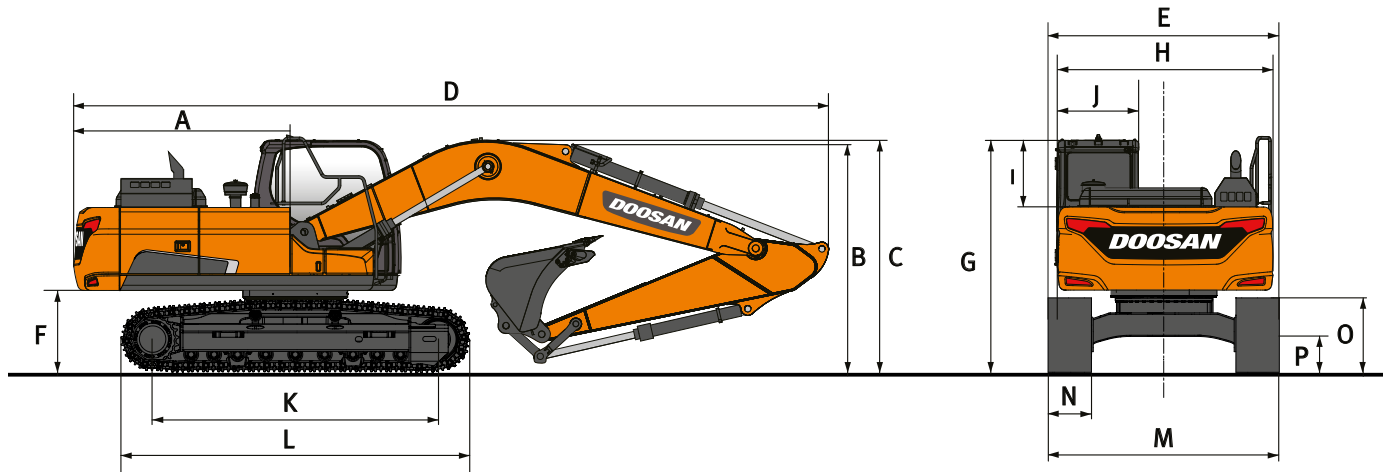

Dimensions

Boom length - mm	One-piece boom			Two-piece boom	
	4600			4980	
Arm length - mm	2100	2500	3000	2100	2500
Bucket capacity - m ³	0.59	0.51	0.45	0.51	0.45
A Tail swing radius - mm	2205	2205	2205	2205	2205
B Shipping height (boom) - mm	2480	2635	3065	2615	2800
C Shipping height (hose) - mm	2640	2820	3180	2840	3000
D Shipping length - mm	7690	7685	7640	8050	7975
E Shipping width - mm	2590	2590	2590	2590	2590
F Counterweight clearance - mm	895	895	895	895	895
G Height over cab - mm	2785	2785	2785	2785	2785
H House width - mm	2540	2540	2540	2540	2540
I Cab height above house - mm	840	840	840	840	840
J Cab width - mm	1010	1010	1010	1010	1010
K Tumbler distance - mm	3035	3035	3035	3035	3035
L Track length - mm	3755	3755	3755	3755	3755
M Undercarriage width std. - mm	2590	2590	2590	2590	2590
N Shoe width std. - mm	600	600	600	600	600
O Track height - mm	795	795	795	795	795
P Ground clearance - mm	410	410	410	410	410

Digging forces (ISO)

Boom length - mm	One-piece boom			Two-piece boom	
	4600			4980	
Arm length - mm	2100	2500	3000	2100	2500
Bucket capacity - m ³	0.59	0.51	0.45	0.51	0.45
BUCKET (Normal/Press. Up) - ton	10.5 / 11	10.5 / 11	10.5 / 11	10.5 / 11	10.5 / 11
ARM (Normal/Press. Up) - ton	7.2 / 7.7	6.2 / 6.5	5.6 / 6.0	7.2 / 7.7	6.2 / 6.5

YOUR ONE SUPPLIER FOR EQUIPMENT HIRE, NATIONWIDE.

Service area: Nationwide | Branches: New Plymouth & Hawera | Phone: 0800 44 10 44 | Email: hire@presco.co.nz